

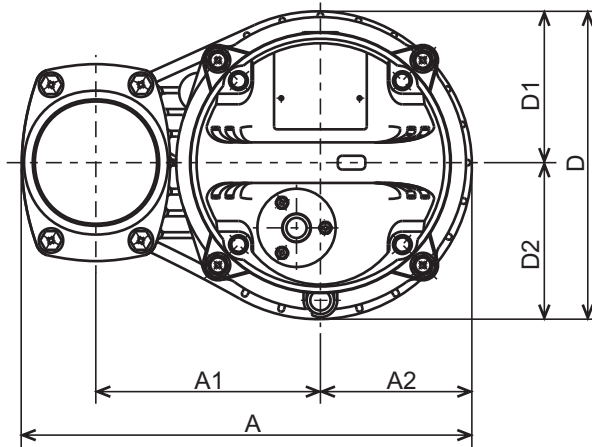

**VANCS - SERIES - PN**  
**(FRP) EFFLUENT PUMPS**

**DIMENSIONS**



**80PSF22.2-61**  
**80PSF23.7-61**

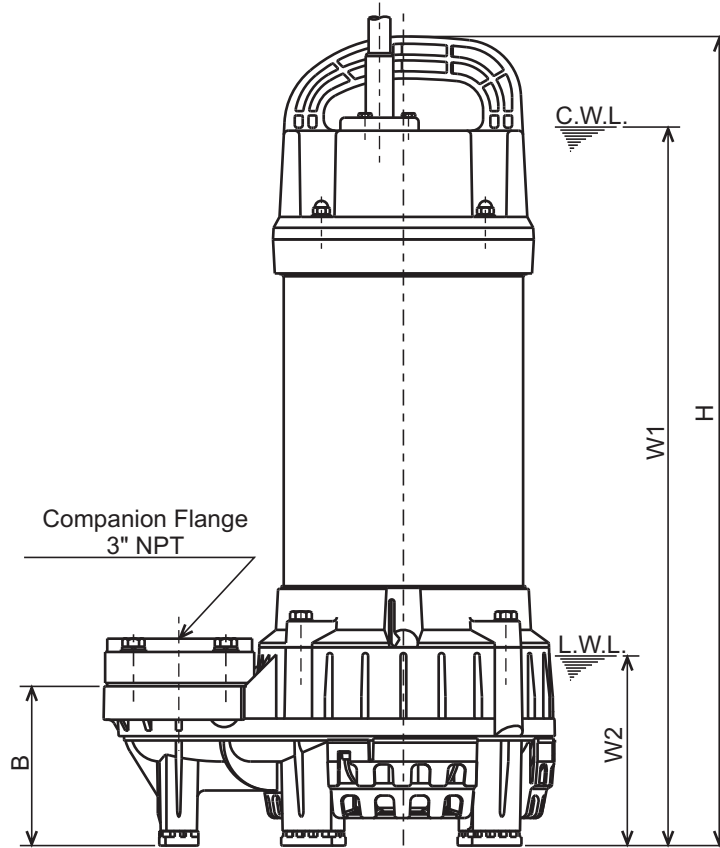

Companion Flange  
3" NPT

C.W.L. : Continuous running Water Level  
L.W.L. : Lowest running Water Level

**DIMENSIONS:USCS (Inch)**

Model	HP	NOM. SIZE	Pump & Motor								C.W.L.	L.W.L.	Wt. (lbs.)
			A	A1	A2	B	D	D1	D2	H	W1	W2	
80PSF22.2-61	3	3"	12 1/4	6 1/8	4 1/8	4 5/16	8 3/8	4 1/8	4 1/4	22	19 5/8	5 1/8	48
80PSF23.7-61	5	3"	12 1/4	6 1/8	4 1/8	4 5/16	8 3/8	4 1/8	4 1/4	23 3/8	21 1/8	5 1/8	59

**DIMENSIONS:METRIC (mm)**

Model	kW	NOM. SIZE	Pump & Motor								C.W.L.	L.W.L.	Wt. (kg)
			A	A1	A2	B	D	D1	D2	H	W1	W2	
80PSF22.2-61	2.2	80	311	155	105	110	212	104	108	559	500	130	22
80PSF23.7-61	3.7	80	311	155	105	110	212	104	108	594	535	130	27



**TSURUMI PUMP**

**VANCS-SERIES PN/PSF/PU**

**DIMENSIONS**

TOK80PN22.2-61  
 TOK80PN23.7-61  
 TOK80PSF22.2-61  
 TOK80PSF23.7-61  
 TOK80PU22.2-61  
 TOK80PU23.7-61

(Slide Rail System  
 TOK2-65T)

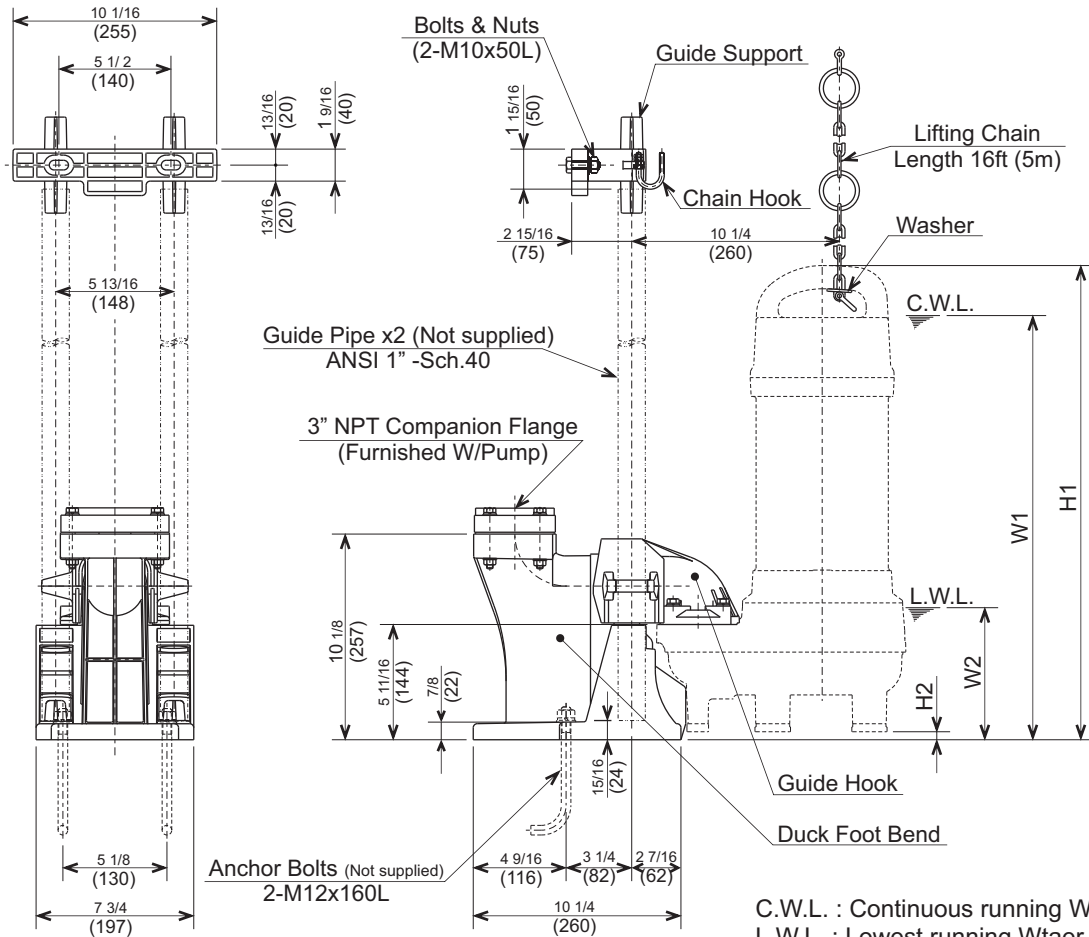
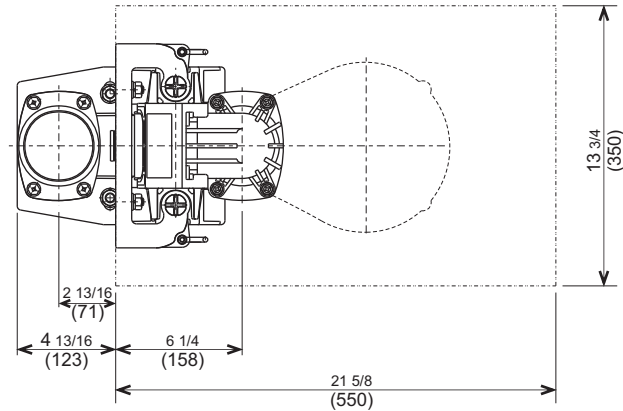

C.W.L. : Continuous running Water Level  
 L.W.L. : Lowest running Water Level

Model	OUTPUT HP (kW)	NOM. SIZE inch (mm)	Dimension inch (mm)				Wt. lbs. (kg)
			H1	H2	C.W.L.	L.W.L.	
					W1	W2	
TOK80PN22.2-61	3 (2.2)	3 (80)	23 3/8 (593)	1 5/16 (34)	20 7/8 (530)	6 1/2 (165)	48 (22)
TOK80PN23.7-61	5 (3.7)	3 (80)	24 3/4 (628)	1 5/16 (34)	22 1/4 (565)	6 1/2 (165)	59 (27)
TOK80PSF22.2-61	3 (2.2)	3 (80)	23 3/8 (593)	1 5/16 (34)	20 7/8 (530)	6 1/2 (165)	48 (22)
TOK80PSF23.7-61	5 (3.7)	3 (80)	24 3/4 (628)	1 5/16 (34)	22 1/4 (565)	6 1/2 (165)	59 (27)
TOK80PU22.2-61	3 (2.2)	3 (80)	23 3/8 (593)	3/8 (10)	20 7/8 (530)	6 1/2 (165)	48 (22)
TOK80PU23.7-61	5 (3.7)	3 (80)	24 3/4 (628)	3/8 (10)	22 1/4 (565)	6 1/2 (165)	59 (27)



## VANCS - SERIES - PSF (FRP) EFFLUENT PUMPS

## PERFORMANCE CURVE

MODEL	BORE	HP	KW	RPM	SOLIDS DIA	LIQUID	SG.	VISCOSITY	TEMP.
80PSF(AW)22.2-61	3"/80mm	3	2.2	3490	0.512"/13mm	Water	1.0	1.123 cSt	60°F
PUMP TYPE	PHASE	VOLTAGE	AMPERAGE	HZ	STARTING METHOD	INS. CLASS			
Effluent Pump	3	208-220/460/575	9.1-8.5/4.2/3.3	60	Direct On Line	E			
CURVE No.	DATE	PHASE	VOLTAGE	AMPERAGE	HZ	STARTING METHOD	INS. CLASS		
-	-	-	-	-	-	-	-		

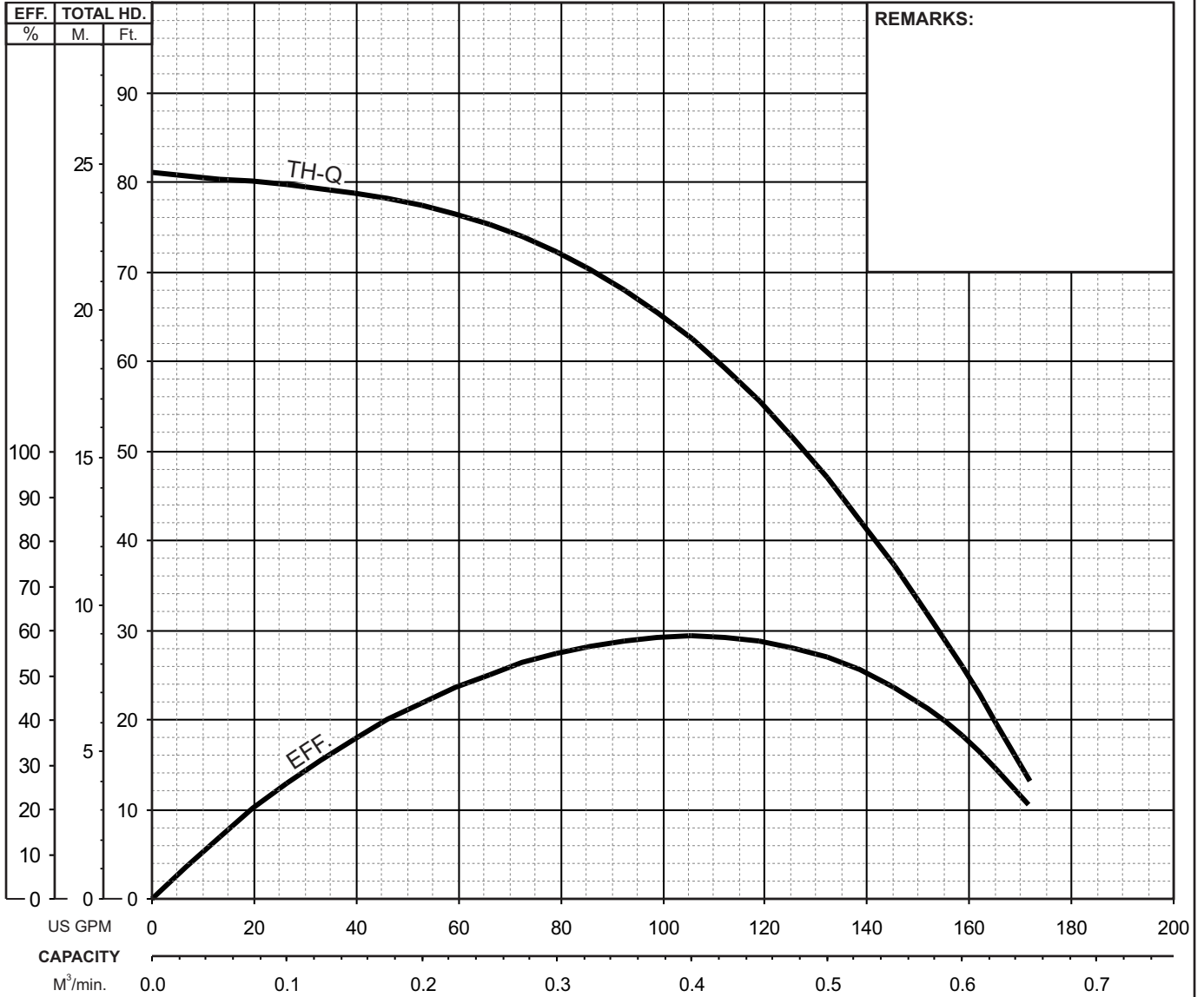



**VANCS - SERIES - PSF**  
**(FRP) EFFLUENT PUMPS**

**SECTIONAL VIEW**

**80PSF22.2-61**  
**80PSF23.7-61**

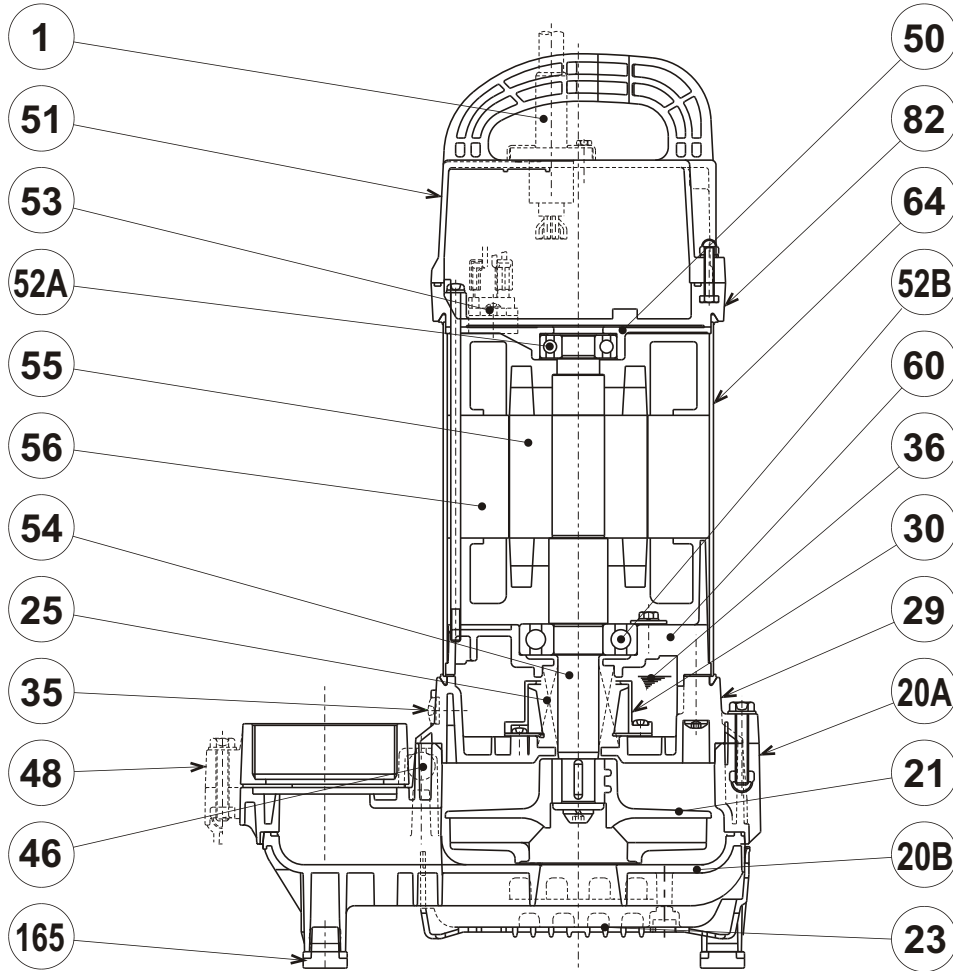

PART#	DESCRIPTION	MAIN MATERIAL / NOTE	RELATED ASTM, AISI CODE	RELATED EN CODE	QTY
1	Power Cable (80PSF22.2-61)	PVC Sheath AWG14/4-32ft			1
	Power Cable (80PSF23.7-61)	PVC Sheath AWG12/4-32ft			
20A	Upper Pump Casing	PA+ABS Plastic w/GF30			1
20B	Lower Pump Casing	PA+ABS Plastic w/GF30			1
21	Impeller	PPO Plastic w/GF20			1
23	Suction Strainer	ABS Plastic			1
25	Mechanical Seal	Silicon Carbide / H-25AT			1
29	Oil Casing	PPS Plastic w/(GF+MD)50			1
30	Oil Lifter	PBT Plastic w/(GF+MD)40			1
35	Oil Plug	Stainless Steel	S 30400	1.4301	1
36	Lubricant	White Mineral Oil ISO VG32			
46	Air Valve	Glass Ball			1
48	Companion Flange	PVC / NPT 3"			1
50	Motor Bracket	Aluminum Alloy Die Casting	B85 383.0	EN 1706 AC-46100	1
51	Motor Head Cover	PPS Plastic w/GF40			1
52A	Upper Bearing	#6204ZZC3			1
52B	Lower Bearing	#6306ZZC3			1
53	Motor Protector				1
54	Shaft	Stainless Steel	S 30400	1.4301	1
55	Rotor				1
56	Stator				1
60	Bearing Housing	Aluminum Alloy Die Casting	B85 383.0	EN 1706 AC-46100	1
64	Motor Housing	Stainless Steel	S 30400	1.4301	1
82	Motor Head Cover Spacer	PPS Plastic w/GF40			1
165	Rubber Cushion	Nitrile Butadiene Rubber			5

PARTS LIST		VANCS WASTEWATER PUMP				6/7/2018
ITEM	PART No.	DESCRIPTION	QTY	SIZE	MATERIAL	NOTES
1	001-149-21	Cabtyre Cable Set (32') 60Hz (USA)	1	VCT4Cx2mm2	BE(40)	
2	143-000-45	Tapping Screw	3	M5x25	SUS304	
3	003-000-13	Gland	1	BECE(P.C.40)	SUS304	included with ITEM#1 cable set
4	051-000-41	Motor Head Cover	1		Resin	
5	141-029-18	Hex.Cap Nut	4	M6	SUS304	
6	142-126-19	Plain Washer	4	M6	SUS304	
7	143-138-17	Truss Tapping Screw	2	M4x12	SWCH	
8	053-001-71	Motor Protector 208/220V-60Hz(USA)	1	KA313-GDXL110	(T)	
	053-411-15	Motor Protector 460/575V-60Hz(USA)	1	KA313-GQXL104	(T)	
9	121-001-22	Packing	1	d169xd176x3.1t(P.C.160)	NBR	*
10	143-000-47	Pan Screw	4	M6x215L(20L)	SWRM	
11	142-113-26	Plain Washer	4	M6(D=11.5)	SPC	
12	082-000-02	Head Cover Spacer	1		Resin	
13	121-001-23	Packing	1	VK(T)-22/37(A)T(W)	NBR	*
14	143-085-34	Pan Screw (w/Spring Washer)	1	M4x6	C3604	
15	009-001-08	Earth Terminal	1Set	2mm2x230L		
16	050-000-63	Motor Bracket	1		ADC	
17	056-005-74	Stator(w/M.Frame) 208/220V-60Hz(USA)	1Set			
	056-005-77	Stator(w/M.Frame) 460V-60Hz(USA)	1Set			
	056-005-78	Stator(w/M.Frame) 575V-60Hz(USA)	1Set			
18	142-000-75	Wave Washer	1	BBA0630300A0,T=0.3	SUP	
19	052-187-16	Bearing (w/O-ring)	1	AC-6204ZC3		
20	055-001-79	Rotor	1Set	w/Bearing		
21	147-000-41	Impeller Key	1	5x5x18.5L	SUS304	
22	140-000-06	Hex.Bolt (w/Spring Washer/Plain Washer)	2	M6x12	SWCH	
23	052-109-14	Bearing	1	6306ZC3		
24	060-001-16	Bearing Housing	1		ADC	
25	025-001-00	Mechanical Seal	1	H-25T (RoHS)	SiC	Supercedes 025-255-12 and 025-000-07
26	143-070-23	Pan Screw	2	M5x6	SWRM	
27	030-143-12	Oil Lifter	1	H-25(A)(T)	Resin	
28	143-193-10	Pan Tapping Screw	2	M5x12	SWRM	
29	030-152-14	Seal Stopper	1	H-25(A)(T)	SPCC	
30	121-001-62	Packing	1	d160.4xd169.4x6.5t(P.C.144)70	NBR	* interchangeable with OLD part# 121-001-20
31	035-127-15	Oil Plug	1	M10x15	SUS304	
32	121-246-11	Packing	1	d10.3xd16x2t	PE	*
33	029-000-88	Oil Casing	1	80PUT22.2/23.7-51/61	Resin	
34	140-000-09	Hex.Bolt (w/Spring Washer)	4	M8x45	SUS304	
35	143-000-46	Truss Screw (w/O-Ring)	6	M6x40(P-5,NBR)	SUS304	*

PARTS LIST		VANCS WASTEWATER PUMP				6/7/2018
ITEM	PART No.	DESCRIPTION	QTY	SIZE	MATERIAL	NOTES
36	021-008-21	Impeller (60Hz)	1	80PSF22.2-61	Resin	
37	142-000-71	Impeller Washer	1	d11xd31x4t	SUS304	
38	142-164-19	Spring Washer	1	M10	SUS304	
39	140-000-65	Hex. Socket Button Head Screw	1	M10x25	SUS304	
40	122-283-13	O-Ring	1	165xd3.1	NBR	*
41	140-000-09	Hex.Bolt (w/Spring Washer)	4	M8x45	SUS304	
42	048-000-75	Screwed Flange	1	NPT-3(1.5kW)	Resin	
43	121-568-12	Packing	1	d84xd98x5t	NBR	*
44	020-002-33	Pump Casing	1	80PN/65PSF22.2/3.7-51/61	Resin	
45	141-121-11	Hex.Nut	2	M8(B=12)	SUS304	
46	165-000-07	Rubber Feet	5	PU/PN/PSF21.5-52/62	NBR	
47	023-001-07	Strainer	1	65PSF22.2/3.7-51/61	Resin	
48	143-000-10	Truss Tapping Screw	4	M4x18	SUS304	
	173-002-35	<b>Packing O-Ring Set</b>	1Set	(Marked by *)		
9	121-001-22	Packing (Head Cover/Head Cover Spacer)	1	d169xd176x3.1t(P.C.160)	NBR	*
13	121-001-23	Packing (Head Cover Spacer/M.Frame)	1	VK(T)-22/37(A)T(W)	NBR	*
30	121-001-62	Packing (M.Frame/O.Casing)	1	d160.4xd169.4x6.5t(P.C.144)70	NBR	* interchangeable with OLD part# 121-001-20
32	121-246-11	Packing (Oil Plug)	1	d10.3xd16x2t	PE	*
35	122-003-17	O-Ring (O.Casing Bolt)	6	P-5(4.8xd1.9)	NBR	*
40	122-283-13	O-Ring (O.Casing/P.Casing)	1	165xd3.1	NBR	*
43	121-568-12	Packing (Screwed Flange)	1	d84xd98x5t	NBR	*
		Lubricant		Liquid Paraffin VG32 680ml		

PARTS LIST		VANCS WASTEWATER PUMP				6/7/2018
ITEM	PART No.	DESCRIPTION	QTY	SIZE	MATERIAL	NOTES

## EXPLODED VIEW

80PSF22. 2-61

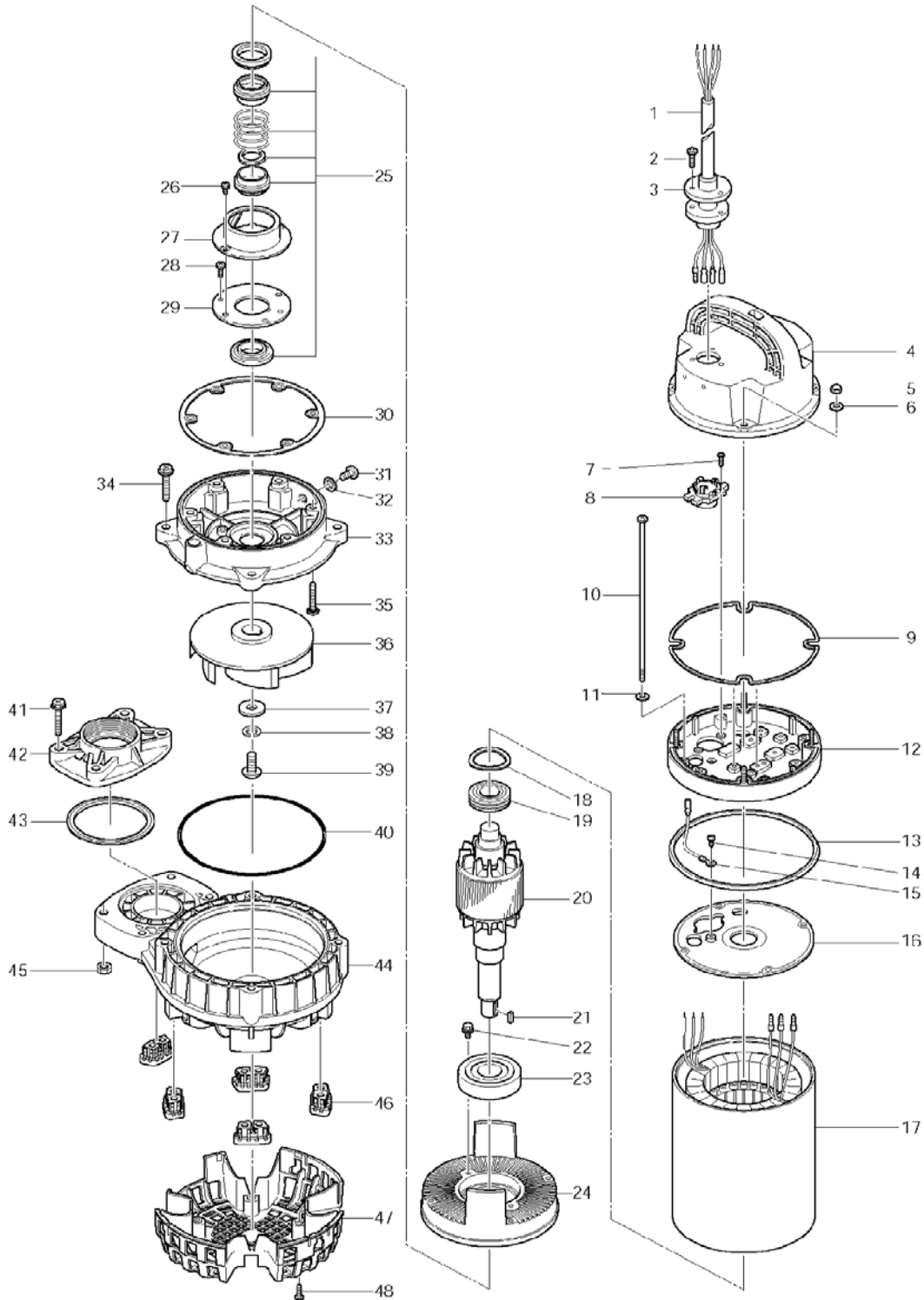

C-01280-1